

JET

JMD-45LPF

MILLING AND DRILLING MACHINE

Original:
GB
Operating Instructions



JPW Tool Group Hong Kong Limited

98 Granville Road, Tsimshatsui East, Kowloon, Hong Kong, PRC

www.jettools.com

Импортер в РФ: ООО «ИТА Технолоджи»

105082, Москва, Переведеновский пер., д. 17

www.jettools.ru

Made in PRC / Сделано в КНР

T – 50000857T

2022-10

In addition to the safety requirements contained in these operating instructions and your country's applicable regulations, you should observe the generally recognized technical rules concerning the operation of metal machines. Any other use exceeds authorization. In the event of unauthorized use of the machine, the manufacturer renounces all liability and the responsibility is transferred exclusively to the operator.

General safety notes

Read and understand the entire instruction manual before attempting assembly or operation.



Keep this operating instruction close by the machine, protected from dirt and humidity, and pass it over to the new owner if you part with the tool. No changes to the machine may be made. Daily inspect the function and existence of the safety appliances before you start the machine. Do not attempt operation in this case, protect the machine by unplugging the power cord.

Before operating the machine, remove tie, rings, watches, other jewellery, and roll up sleeves above the elbows.

Remove all loose clothing and confine long hair.

Wear safety shoes; never wear leisure shoes or sandals.

Always wear the approved working outfit:

- safety goggles
- ear protection



Do not wear gloves while operating this machine.



Install the machine so that there is sufficient space for safe operation and workpiece handling.

Keep work area well lighted.

The machine is designed to operate in closed rooms and must be bolted stable on firm and levelled table surface or on the supplied cabinet stand.

Make sure that the power cord does not impede work and cause people to trip.

Keep the floor around the machine clean and free of scrap material, oil and grease.

Stay alert!

Give your work undivided attention.

Use common sense. Do not operate the machine when you are tired.

Keep an ergonomic body position. Maintain a balanced stance at all times.

Do not operate the machine under the influence of drugs, alcohol or any medication. Be aware that medication can change your behaviour.



Never reach into the machine while it is operating or running down.



Keep children and visitors a safe distance from the work area. Never leave a running machine unattended. Before you leave the workplace switch off the machine.

Do not operate the electric tool near inflammable liquids or gases. Observe the fire fighting and fire alert options, for example the fire extinguisher operation and place.

Do not use the machine in a damp environment and do not expose it to rain.

Before machining, remove any nails and other foreign bodies from the workpiece.

Work only with well sharpened tools.

Machine only stock which rests securely on the table. Always close the chuck cover before you start the machine.

Specifications regarding the maximum or minimum size of the workpiece must be observed.

Do not remove chips and workpiece parts until the machine is at a standstill.

Do not stand on the machine.

Connection and repair work on the electrical installation may be carried out by a qualified electrician only.



Have a damaged or worn power cord replaced immediately.

Make all machine adjustments or maintenance with the machine unplugged from the power source.



Do not over extrude material from the back of spindle bore while machine running.



WARNING:FAILURE TO FOLLOW THESE RULES MAY RESULT IN SERIOUS PERSONAL INJURY

As with all machinery there are certain hazards involved with operation and use of the machine. Using the machine with respect and caution will considerably lessen the possibility of personal injury. However, if normal safety precautions are overlooked or ignored, personal injury to the operator may result.

This machine was designed for certain applications only. We strongly recommends that this machine. NOT be modified and/or used for any application other than for which it was designed. If you have any questions relative to its application DO NOT use the machine until you have had detail instruction form your dealer.

SAFTEY RULES FOR ALL TOOLS

1.FOR YOUR OWN SAFETY , READ THIS INSTRUCTION MANUAL BEFORE OPERATING THE TOOL. Learn the tool's application and limitations as well as the specific hazards peculiar to it.

2.KEEP GUARDS IN PLACE and in working order.

3.GROUND ALL TOOLS. If tool is equipped with three-prong plug, it should be plugged into a three-hole electrical receptacle. If an adapter is used to accommodate a two-prong plug receptacle, the adapter lug must be attached to a know ground . Never remove the thrid prong.

4.REMOVE ADJUSTING AND WRENCHES.

Form habit of checking to see that keys and adjusting wrenched are removed form tool before turning it "on."

5.KEEP WORK AREA CLEAN. Cluttered areas and benches invite accidents.

6.DON'T USE IN DANGEROUS ENVIRONMENT. Don't use power tools in damp or wet locations, or expose them to rain. Keep work area well-lighted.

7.KEEP CHILDER AND VISITORS AWAY. All children and visitors should be keep a safe distance form work area.

8.MAKE WORKSHOP CHILDROOF-with padlocks, master switches, or by removing starter keys.

9.Don't force tool. It will do the job better and be safer at the rate for which it was designed.

10.USE RIGHT TOOL. Don't force tool or attachment to do a job for which it was not designed.

11.WEAR PROPER APPAREL. No loose clothing , gloves , neckties , rings ,

bracelets, or other jewelry to get caught in moving parts. Nonslip foot wear is recommended . Wear protective hair covering to contain long hair.

12.ALWAYS WEAR EYE PROTECTION. Refer to ANSIZ87.1 Standard for appropriate recommendations . Also use face or dust mask if cutting operation is dusty.

13.SECURE WORK. Use clamps or a vise to hold work when practical. It's safer than using your hand and frees both hands to operate tool.

14.DON'T OVERREACH. Keep proper footing and balance at all times.

15.MAINTAIN TOOLS IN TOP CONDITION.

Keep tool sharp and clean for best and safest performance. Follow instructions for lubricating and changing accessories.

16.DISCONNECT TOOLS before servicing and when changing accessories such as blades,bits cutters,etc.

17.USE RECOMMENDED ACCESSORIES.

Consult the owner's manual for recommended accessories. The use of improper accessories may cause hazards.

18.AVOID ACCIDENTAL STARTING. Make sure switch is in "OFF" position before plugging in power cord.

19.NEVER STAND ON TOOL. Serious injury could occur if the tool is tipped or if the cutting tool is accidentally contacted.

20.CHECK DAMAGED PARTS. Before further use of the tool, a guard or other part that is damaged should be carefully checked to ensure that it will operate properly and perform its intended function check for alignment of moving parts binding of moving parts,breakage of parts mounting , and any other conditions that may affect its operation.A guard or other part that is damaged should be properly repaired or replaced.

21.DIRECTION OF FEED. Feed work into a blade or cutter against the direction of rotation of the blade or cutter only.

22.NEVER LEAVE TOOL RUNNING UNATTENDED.TURN POWER OFF. Don't leave tool until it comes to a complete stop.

23.DRUGS ALCOHOL, MEDICATION. Do not operate tool while under the influence of drug,alcohol or any medication.

24.MAKE SURE TOOL IS DISCONNECTED FORM POWER SUPPLY while motor is being mounted, connected or reconnected.

ADDITIONAL SAFETY RULES FOR MILL DRILL

1. **BE SURE** drill bit or cutting tool is securely locked in the chuck.
2. **BE SURE** chuck key is remove form the chuck before turning on power .
3. **Adjust** the table or depth stop to avoid drilling into the table.
4. **SHUT OFF** the power , remove the drill bit or cutting tool, and clean the table before leaving the machine.
5. **CAUTION.** When practical, use clamps or a vise to secure workpiece to keep the workpiece form rotating while the drill bit or cutting tool.
6. **WARNING: FOR Your Own Safety** Don't wear gloves when operating a mill/drill.

SPECIFICATION

Model	JMD-45LPF
Max. drilling capacity (Iron/Steel)	45mm/32mm
Max. milling capacity (Face milling)	80mm
Max. milling capacity (End milling)	32mm
Spindle taper	ISO30
Spindle travel	120mm
Worktable size	1000x240mm
T-slot size	3x14mm
Worktable travel	760/190mm
Distance between spindle to column	258mm
Max. distance between spindle nose to worktable	450mm
Swing of headstock	±45°
Spindle speed (12 steps)	75, 180, 280, 600, 1000, 1600
	150, 360, 560, 1200, 2000, 3200
Motor power	1.1/1.5kw
NW/GW	315/345kg
Packing size	1240x760x1150mm

WARNING: CHANGE SPEED ONLY WHEN MACHINE IS STOPPED CHANGING THE GEAR BOX OIL

Tilt the head stock over as shown in Fig 1. Open the drain plug to allow the oil to drain form the opening completely. Then lock the oil drain plug and turn the head to be upright position. Remove the oil filler plug fill the oil to the gear until the oil lever reach the middle of oil fluid lever indicator. Then lock the plug.

CLEANNING

- (1) Your machine has been coated with a heavy grease to protect it in shipping. This coating should be completely removed before operating the machine. Commercial degreaser , kerosene or similar solvent may be used to remove the grease form the machine, but avoid getting solvent ob belts or other rubber parts.
- (2) After cleaning , coat all bright work with a light lubrication. Lubricate all points with a medium consistency machine oil.

LUBRICATION:

All ball bearings in your mill/drill are sealed for lift,requiring no lubrication.

Points requiring lubrication are:

- (1) Internal spline drive assembly. Keep this area well lubricated with a good grade grease, insert grease in the hole at the top of spindle pulley spline driver, lube twice yearly.
- (2) A light film of oil applied to the quill and column will reduce wear,prevent rust, and assure ease of operation.
- (3) Quill return spring should receive oil (sae 20) once yearly. Remove cover plate and apply oil with squirt can or small brush.
- (4) **IMPORTANT:**The gear box should be oiled with a lubricant such as sae 68 oil in level. **CHANGE OIL EVERY ONE YEAR.**
- (5) Apply lubriplate to quill pinion every 90 days.

NOTE: use extreme care when performing this operation and keep hands clear of pinch points. When using paraffin bar , do this only by turning the sheaves by hand. Do not apply with motor running.

USE OF MAIN MACHINE PARTS

- (1) To raise and lower the head by head handle.
- (2) Equipped with an electric switch for tapping operation clockwise or counterclock wise.
- (3) To adjust the quick or slow feeding by feed handle.
- (4) To adjust the table left and right travel by table handle wheel.
- (5) To adjust the table fore and after travel by table handle wheel.
- (6) To operate the spindle handle wheel for micro feed.
- (7) To adjust the scale size according to working need.

PRECAUTION OPERATION

Check all parts for proper condition before operation ; if normal safety precautions are nnoticed carefully, this machine can provide you withstanding of accurate service.

- (1) Before Operation
 - (a) Fill the lubricant
 - (b) In order to keep the accurate precision, the table must be free from dust and oil deposits.
 - (c) Check to see that the tools are correctly set and the workpiece is set firmly.
 - (d) Be sure the speed is not set to fast.
 - (e) Be sure everything is ready before use
- (2) After Operation
 - (a) Turn off the electric switch.
 - (b) Turn down the tools.
 - (c) Clean the machine and coat it with lubricant.
 - (d) Cover the machine with cloth to keep out the dust.
- (3) Adjustment of head
 - (a) To raise and lower the head, loosen the leaf screw located on the right side of the raise and lower base. When the desired height is reached tighten leaf screw to avoid vibration.
 - (b) Unscrew 3 nuts while the workpiece needs to be bevel turn to the degrees you wish on the scale, then screw the 3.

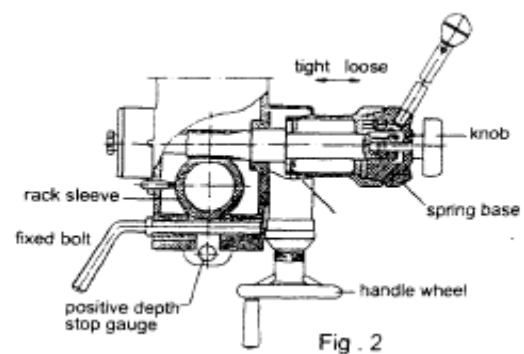
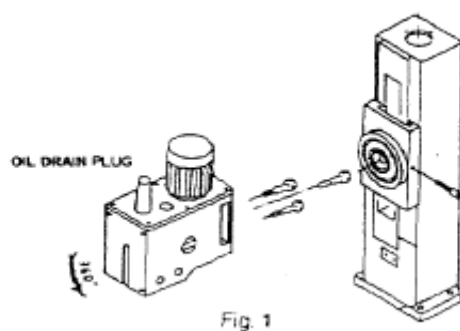

QUILL RETURN SPRING ADJUSTMENT:

Spring tension for return of spindle , after hole drilling, has been pre-set at the factory. No further adjustment should be attempted unless absolutely necessary. Adjustment will probably be required if a multiple spindle drilling or tapping head is used. If adjustment is necessary , loosen lock screw while holding quill spring housing. Do not allow the housing to turn in your hand , or spring will unwind. Turn entire housing assembly clockwise the number of turns necessary to cause the quill to return to its up position. (NOTE: The flat

of the spring housing pilot is lined up with the spring loading hole on the body of the spring housing.) Reset lockscrew make sure point of screw mates the flat on the housing journal.

(1) Preparing for Drilling (see fig.2)(Except addition power feed system).

Turn of the knob make loose the taper body of worm gear and spring base. Then we decide spindle stroke setting the positive depth stop gauge for drilling blind hole or free state for pass hole.

(2) Preparing for milling(see fig.2)(Except addition power feed system)

- (a) Adjust the positive depth stop gauge to highest point position.**
- (b) Turn tight of the knob be use to taper friction force coupling the worm gear and spring base. Then turning the handle wheel by micro set the spindle of work piece machining height.**
- (c) Lock the rack sleeve at the desired height with fixed bolt.**

ADJUSTING TABLE SLACK AND COMPENSATE FOR WEAR(see fig.3)

- (1) Your machine is equipped with jib strip adjustment to compensate for wear and excess slack on cross and longitudinal travel.**
- (2) Clockwise rotation the job strip bolt with a big screw for excess slack otherwise a little counter cloclwise if too tight.**
- (3) Adjust the jib strip bolt until feel a slight drag when shifting the table.**

CLAMPING TABLE BASE AND MACHINE BASE (See Fig.3)

(1)When milling longitudinal feed. It is advisable to lock the cross feed table travel to insure the accuracy of your work. To do this , tighten the small leaf

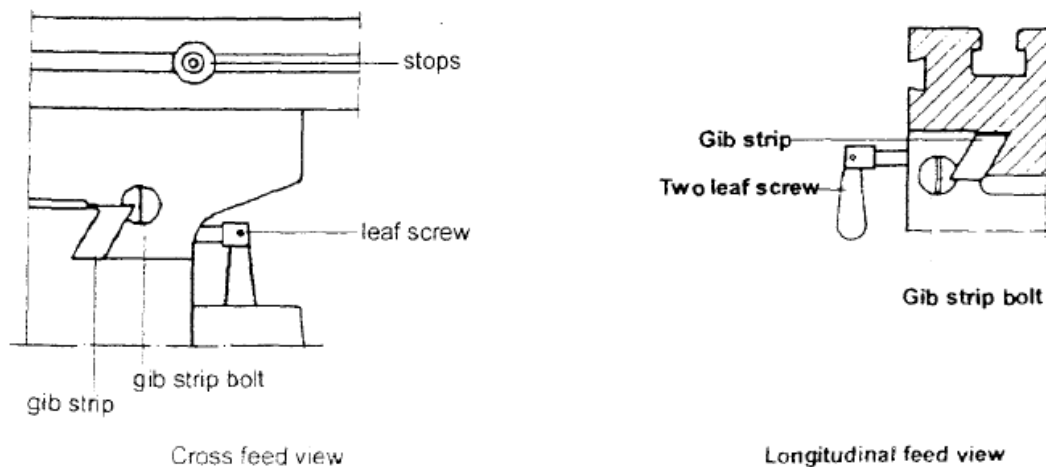

Fig.3

(2) To tighten the longitudinal feed travel of the table for cross feed milling, tighten the two small leaf screw on the front of the table base.

(3) Adjustable travel stops are provide on the front of the table for control of cross travel and the desired milling length.

TO CHANGE TOOLS

(1) Removing Face Mill or Drill Chuck Arbor

Loosen the arbor bolt at the top of the spindle shaft approximately 2 turns with a wrench. Rpa the top of the arbor bolt with a mallet.

After taper has been broken loose, holding chuck arbor on hand and turn detach the arbor bolt with the other hand.

(2) To install Face Mill or Cutter Arbor

Insert cutter and cutter arbor bolt detach securely, but do not over-tighten.

(3) Removing Taper Drills

(a) Turn down the arbor bolt and insert the taper drill into the spindle shaft.

(b) Turn the rapid down handle rod down until the oblong hole in the rack sleeve appears. Line up this hole with the hole in the spindle. Insert key punch key through holes and strike lightly with a mallet. This will force the taper drill out.

SPECIFICATION OF T-SLOT

The size of T-Solt on table as fig.4

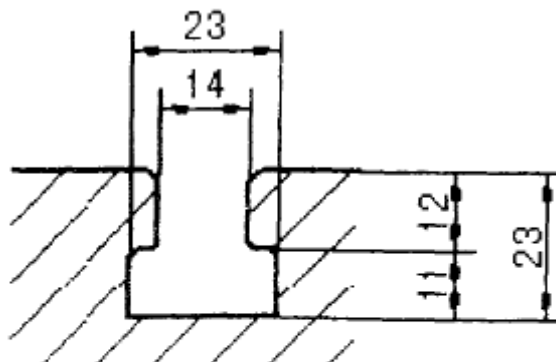
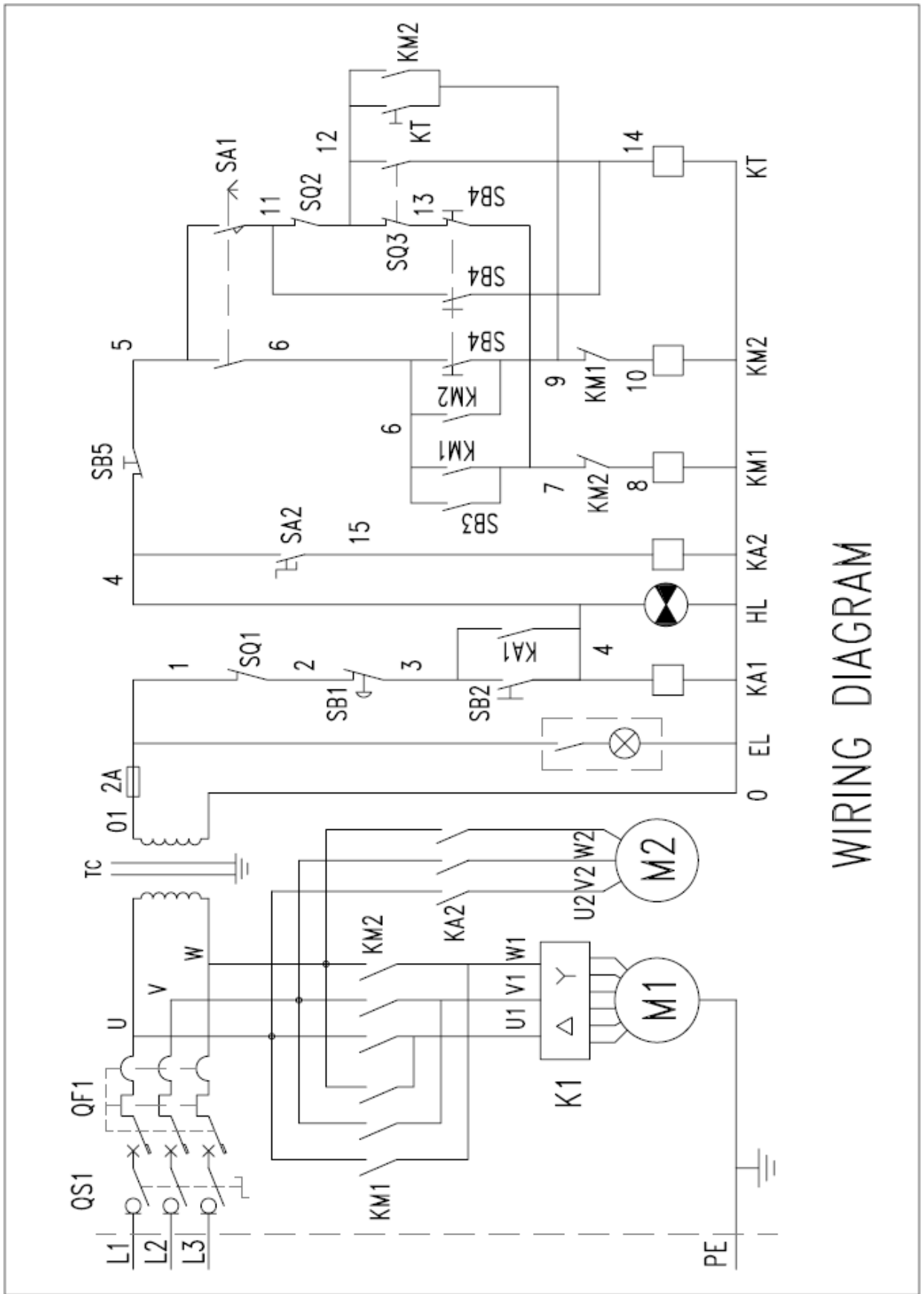

Fig.4

TROUBLE SHOOTING HINTS

TROUBLE	PROBABLE CAUSE	REMEDY
Excessive Vibration	<ol style="list-style-type: none"> 1.Motor out of balance 2.Bad motor 	<ol style="list-style-type: none"> 1.Balance or replace problem motor. 2.Replace motor
Motor stalls	<ol style="list-style-type: none"> 1.Over feeding. 2.Dull drill. 3.Motor not building up to running speed. 4.Bad motor 	<ol style="list-style-type: none"> 1.Replace feed rate. 2.Sharpen drill and keep sharp. 3.Replace or repair motor .Check fuses in all three legs on three phase motors and replace if necessary. 4.Replace motor
Noisy Operation	<ol style="list-style-type: none"> 1.Excessive vibration 2.Improper quill adjustment. 3.Nosiy spline. 4.Noisy motor 	<ol style="list-style-type: none"> 1.Check remedy under excessive vibration. 2.Adjust quill. 3.Lubricate spline. 4.Check motor bearing or for loose motor fan.
Drill or Tool heats up or burns work	<ol style="list-style-type: none"> 1.Excessive speed. 2.Chips not clearing. 3.Dull tool. 4.Feed reate too slow. 5.Rotation of drill incorrect. 6.Failure to use cutting oil or coolant (on steel) 	<ol style="list-style-type: none"> 1.Readuce speed. 2.Use pecking operation to clear chips. 3.Sharpen tool or replace. 4.Increase feed enough to clear chips. 5.Reverse motor rotation. 6.Use cutting oil or coolant on steel
Drill leads off	<ol style="list-style-type: none"> 1.No drill spot. 2.Cutting lips on drill off center. 3.Quill loose in head. 4.Bearing play. 	<ol style="list-style-type: none"> 1.Center punch or center drill workpiece. 2.Regrind drill. 3.Tighten quill. 4.Check bearings and reseal or replace if necessary.
Excessive drill runout or wobble	<ol style="list-style-type: none"> 1.Bent drill. 2.Bearing play. 3.Drill not seated properly in chucks. 	<ol style="list-style-type: none"> 1.Replace drill.Do not attempt to straighten. 2.Replace or reseal bearings. 3.Loosen , reseal and tighten chuck.
Work or fixture comes loose or spins	<ol style="list-style-type: none"> 1.Failure to clamp workpiece or work holding device to table. 	<ol style="list-style-type: none"> 1.Clamp workpiece or work holding device to table surface.



WIRING DIAGRAM

JMD-45LPF

NO	Electrical code	Model and Specification	Function description	Supplier
1	QS1	JCH13-20 20/41000	Change-over switch	JUCHE
2	TC	JBK5-63VA	Transformer	AOHENG
3	FU	2A	FUSE	ZHENGRONG
4	QF1	JCM6-25	Circuit breaker	JUCHE
5	SB1	LA125H-BS542	Emergency stop button	MINGER
6	SB2	LA125J-11D/206A	Start button	MINGER
7	SB3	LA125H-BA31	Forward	MINGER
8	SB4	LA125H-BA31	Reverse	MINGER
9	SB5	LA125H-BA42	stop button	MINGER
10	SA1	LA125H-BD33	Drilling milling /Tapping	MINGER
11	SA2	LA125H-BD21	Cooling pump button	MINGER
12	SQ1	KW-7	Spindle protect	LEMA
13	SQ2	KW3-OZ	Tapping limit switch	BINGSHUANG
14	SQ3	KW3-OZ	Tapping limit switch	BINGSHUANG
15	KM1	3TB41	Contactor	SIEMENS
16	KM2	3TB41	Contactor	SIEMENS
17	KA1	HH52P-L	Auxiliary relay	E&E
18	KA2	HH54P-L	Auxiliary relay	E&E
19	KT	H3Y-2	Time relay	OMRON
20	EL	JC34A	LED working lamp	JINYE
21	K1	LW28-20/5	Double Speed Switch	JUCHE
22	M1	JMD40-A7 (YD90L-4/2)	MOTOR	DONGTAI
23	M2	DB-12	Cooling pump	DONGTAI

OPERATION PROCEDURE

Manual feed

Turn the power feed switch 1 off, handle 4 with be vertical with the axis of Spindle stroke dial 3, rotate limited screw 5 and be contacted with handle 4, then can be manually feed spindle.

When the power feed switch 1 on, make handle 4 vertical , locked limited screw 5, rotate Speed leve 2 to “0” , then can be manually feed spindle.

When want to trade off manual feed and power feed, stop the machine and turn on power feed switch 1 and speed lever 2. Make handle 4 vertical can be manually feed Spindle, Push handle 4 right can be power feed Spindle.

Power feed

Turn on Power feed switch 1 and Speed lever 2, Start the machine and push handle 4 right can be power feed spindle , the machine can be automatically shut down when spindle arrived at the designed Depth.(max Depth 120mm,availability Depth 115mm), and spindle send back.Turn Speed lever 2 can realize 0.10, 0.18, 0.26 three kinds depth feed to choose.

Want to make the machine spindle direct into power fed,loose locket nut 6, make Spindle stroke dial 3 to max stroke depth dial position, tighten locked nut 6 form Spindle stroke dial 3 can read spindle the position.

Adjustment power feed depth

Move spindle to the designed position , shut down the machine . Push handle 4 right , loose locked nut 6, adjusted Sindle stroke dial 3, make the deisgned dial level with “0”,locked Spindle stroke dial 3, start the machine can power feed. Automatically shut down when spindle arrived at the designed Depth, and spindle send back. During power feed, make handle 4 vertical can stop power feed. Make handle 4 vertical can stop power feed. Need to use micro feed device, rotate Speed lever 2 to “0”, push handle 4 right, loose locked screw 8, adjust mirco feed dial 7 to “0”, tighten locked screw 8, totate hand wheel 9 can realize micro feed.

The system have safety clutch device, and be on use estate before leave factory. When clutch invalidation because of fray, and want to adjustment, can take away the panel and adjust spring can immediately recover the

JMD-45LPF Spindle Power Feed - A

No.	Part No.	Code	Name	Size	Qty.
1	JMD45LPF-A1	20102	Feed box		1
2	JMD45LPF-A2	20234	Pinion shaft		1
3	JMD45LPF-A3	20243	Spindle stroke dial		1
4	JMD45LPF-A4	20242	Clutch bushing set		1
5	JMD45LPF-A5	20241	Backing pin		1
6	JMD45LPF-A6		Pin	6x12	1
7	JMD45LPF-A7	20247	Ball head pin		1
8	JMD45LPF-A8		Pin	4x10	2
9	JMD45LPF-A9	20239	Square thread set		1
10	JMD45LPF-A10	20240	Square thread nut		1
11	JMD45LPF-A11	20244	Handle body		1
12	JMD45LPF-A12	20245	Washer		1
13	JMD45LPF-A13	20203	Handle		2
14	JMD45LPF-A14	20237	Clutch key base set		1
15	JMD45LPF-A15	20236-2	Bush		1
16	JMD45LPF-A16	20236-1	Worm gear		1
17	JMD45LPF-A17	20231	Clutch screw set		2
18	JMD45LPF-A18	20235	Screw		2
19	JMD45LPF-A19	20232	Spring		2
20	JMD45LPF-A20	20223	II shaft		1
21	JMD45LPF-A21		Bearing	6003	2
22	JMD45LPF-A22	20215	Change gear lever set		1
23	JMD45LPF-A23	20220	Spring		1
24	JMD45LPF-A24	20222	Pull key		1
25	JMD45LPF-A25		Pin	2x10	2
26	JMD45LPF-A26	20304	Worm gear		1
27	JMD45LPF-A27		Key	8x16	1
28	JMD45LPF-A28	20217	Bushing		2
29	JMD45LPF-A29	20218	Gear		1
30	JMD45LPF-A30	20219	Gear		1
31	JMD45LPF-A31	20221	Gear		1
32	JMD45LPF-A32	20216	Bushing bracket		1
33	JMD45LPF-A33		Retainer ring	24	2
34	JMD45LPF-A34		Retainer ring	35	1
35	JMD45LPF-A35		Key	4x8	2
36	JMD45LPF-A36		Screw	M4x12	3
37	JMD45LPF-A37	20202	Gear		1
38	JMD45LPF-A38	20201	Speed lever		1
39	JMD45LPF-A39		Steel ball	8	1
40	JMD45LPF-A40		Retainer ring	12	2

JMD-45LPF Head Parts For Spindle Power Feed - B

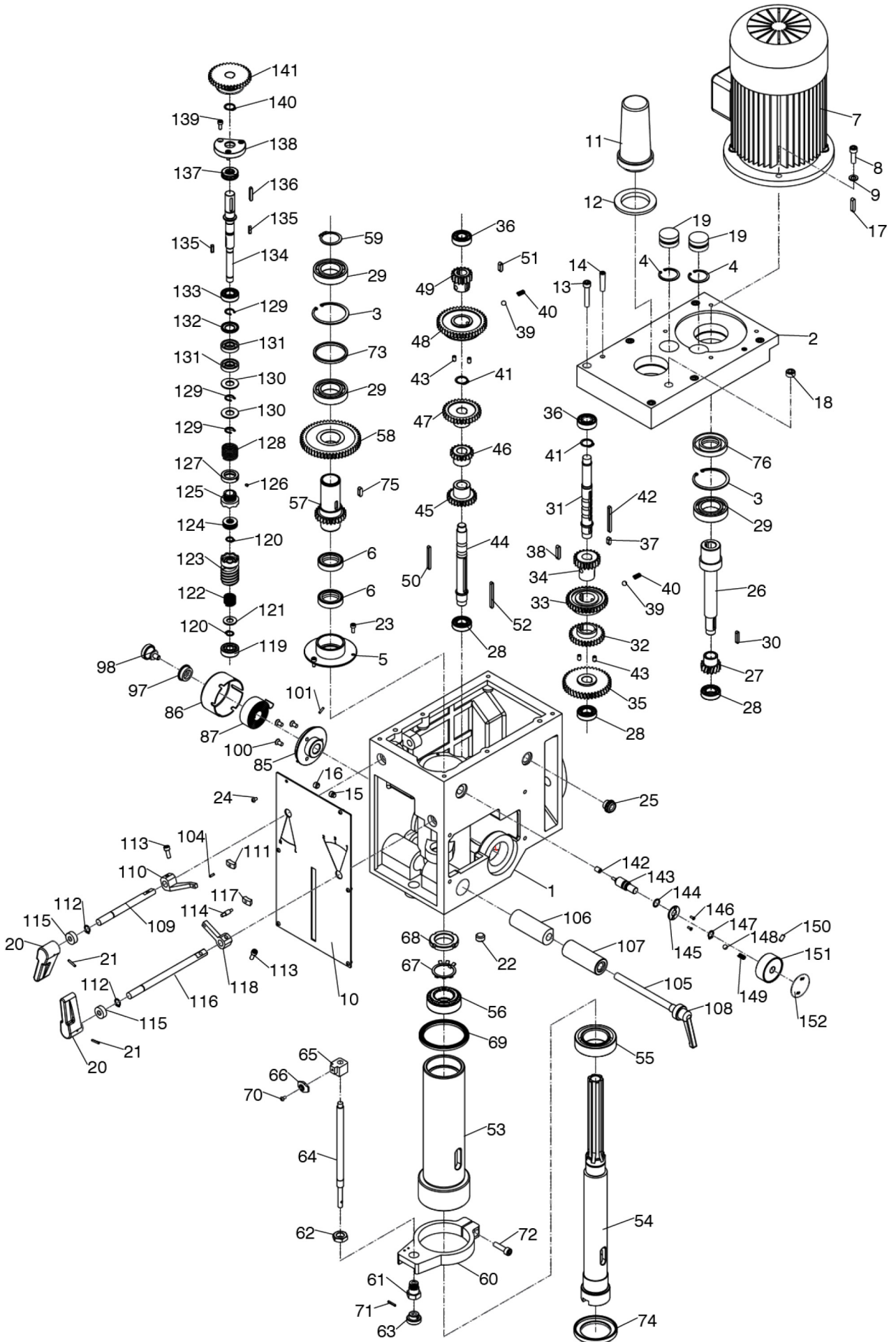

JMD-45LPF Head Parts For Spindle Power Feed - B

No.	Part No.	Code	Name	Size	Qty.
1	JMD45LPF-B1	20010B	Head body		1
2	JMD45LPF-B2	20011B	Head body cover		1
3	JMD45LPF-B3		Retaining ring	62	2
4	JMD45LPF-B4		Retaining ring	35	2
5	JMD45LPF-B5	20018B	Airtight base		1
6	JMD45LPF-B6		Airtight ring	FB45x35x10	2
7	JMD40-A7		Motor		1
8	JMD45LPF-B8		Screw	M8x25	1
9	JMD45LPF-B9		Washer	8	1
10	JMD45LPF-B10	20201	Plate		1
11	JMD45LPF-B11	20304-1B	Arbor bolt cover		1
12	JMD45LPF-B12	20304-2B	Arbor bolt cover base		1
13	JMD45LPF-B13		Screw	M8x45	6
14	JMD45LPF-B14		Pin	8x40	2
15	JMD45LPF-B15		Screw	M10x10	1
16	JMD45LPF-B16		Screw	M10x8	1
17	JMD45LPF-B17		Key	8x28	1
18	JMD45LPF-B18		Bolt	ZG3/8	1
19	JMD45LPF-B19	20020B	Cap		2
20	JMD45LPF-B20	20307B	Speed lever		2
21	JMD45LPF-B21		Pin	3x18	2
22	JMD45LPF-B22		Oil plug	ZG3/8	1
23	JMD45LPF-B23		Screw	M5x10	3
24	JMD45LPF-B24		Screw	M4x8	6
25	JMD45LPF-B25		Oil pointer	M18x1.5	1
26	JMD45LPF-B26	20105B	I shaft		1
27	JMD45LPF-B27	20105-1-B	Gear		1
28	JMD45LPF-B28		Bearing	6003	3
29	JMD45LPF-B29		Bearing	6007	3
30	JMD45LPF-B30		Key	5x25	1
31	JMD45LPF-B31	20106B	II shaft		1
32	JMD45LPF-B32	20108-B	Gear		1
33	JMD45LPF-B33	20110-1-B	Gear		1
34	JMD45LPF-B34	20111-B	Gear		1
35	JMD45LPF-B35	20106-1-B	Gear		1
36	JMD45LPF-B36		Bearing	6202	2
37	JMD45LPF-B37		Key	6x14	1
38	JMD45LPF-B38		Key	6x28	1
39	JMD45LPF-B39		Ball	8	2
40	JMD45LPF-B40		Spring		2

JMD-45LPF Head Parts For Spindle Power Feed - B

No.	Part No.	Code	Name	Size	Qty.
41	JMD45LPF-B41		Retaining ring	18	2
42	JMD45LPF-B42		Key	5x50	1
43	JMD45LPF-B43		Screw	M6x8	4
44	JMD45LPF-B44	20107B	III shaft		1
45	JMD45LPF-B45	20109-B	Gear		1
46	JMD45LPF-B46	20110-2-B	Gear		1
47	JMD45LPF-B47	20112-B	Gear		1
48	JMD45LPF-B48	20113-B	Gear		1
49	JMD45LPF-B49	20115-B	Gear		1
50	JMD45LPF-B50		Key	5x50	1
51	JMD45LPF-B51		Key	6x18	1
52	JMD45LPF-B52		Key	6x75	1
53	JMD45LPF-B53	20019	Spindle sleeve		1
54	JMD45LPF-B54	20104B	Spindle		1
55	JMD45LPF-B55		Bearing		1
56	JMD45LPF-B56		Bearing		1
57	JMD45LPF-B57	20114-B	Splined sleeve		1
58	JMD45LPF-B58	20116-B	Gear		1
59	JMD45LPF-B59		Retaining ring	35	1
60	JMD45LPF-B60	20012	Feed base		1
61	JMD45LPF-B61	20128	Support base		1
62	JMD45LPF-B62	20129	Nut		1
63	JMD45LPF-B63	20130	Knob		1
64	JMD45LPF-B64	20131	Graduated rod		1
65	JMD45LPF-B65	20021	Fixed bolt		1
66	JMD45LPF-B66	20132	Scale board		1
67	JMD45LPF-B67		Lock washer	35	1
68	JMD45LPF-B68		Lock nut	M35x1.5	1
69	JMD45LPF-B69	20308	Rubber washer		1
70	JMD45LPF-B70		Screw	M4x8	1
71	JMD45LPF-B71		Split pin	3x18	1
72	JMD45LPF-B72		Bolt	M8x30	1
73	JMD45LPF-B73	20024B	Separating ring		1
74	JMD45LPF-B74	20133B	Oil tight cover		1
75	JMD45LPF-B75		Key	6x18	1
76	JMD45LPF-B76		Oil seal	FB62x35x10	1
85	JMD45LPF-B85	20118	Spring base		1
86	JMD45LPF-B86	20123	Spring cap		1
87	JMD45LPF-B87	20122	Spring plate		1
97	JMD45LPF-B97	203063	Washer		1

JMD-45LPF Head Parts For Spindle Power Feed - B

No.	Part No.	Code	Name	Size	Qty.
98	JMD45LPF-B98	203066	Bolt		1
100	JMD45LPF-B100		Screw	M6x12	3
101	JMD45LPF-B101		Pin	3x12	2
104	JMD45LPF-B104		Pin	3x15	1
105	JMD45LPF-B105	20124B	Fixed bolt		1
106	JMD45LPF-B106	20203B	Fixed tight block		1
107	JMD45LPF-B107	20202B	Fixed tight block		1
108	JMD45LPF-B108		Adjust handle		1
109	JMD45LPF-B109	20125B	Lever shaft		1
110	JMD45LPF-B110	2022-1B	Lever		1
111	JMD45LPF-B111	20204-2B	Lever bracket		1
112	JMD45LPF-B112		Retaining ring	12	2
113	JMD45LPF-B113		Screw	M6x16	2
114	JMD45LPF-B114	20204-3B	Lever rod		1
115	JMD45LPF-B115		Oil seal	12x22x8	2
116	JMD45LPF-B116	20216B	Long lever shaft		1
117	JMD45LPF-B117	20204-1B	Lever bracket		1
118	JMD45LPF-B118	20022-2B	Lever		1
119	JMD45LPF-B119		Bearing	6201	1
120	JMD45LPF-B120		Retaining ring	12	2
121	JMD45LPF-B121		Washer	12	1
122	JMD45LPF-B122	20209	Spring		1
123	JMD45LPF-B123	20207A	Worm shaft		1
124	JMD45LPF-B124		Bearing	51101	1
125	JMD45LPF-B125	20208B	Clutch base		1
126	JMD45LPF-B126		Screw	M4x5	1
127	JMD45LPF-B127		Locked out	M22x1.5	1
128	JMD45LPF-B128	20205B	Spring		1
129	JMD45LPF-B129		Retaining ring	15	3
130	JMD45LPF-B130	20108A	Washer		2
131	JMD45LPF-B131		Oil seal	FB15x32x7	2
132	JMD45LPF-B132	20103A	Fixed sleeve		1
133	JMD45LPF-B133		Bearing	6002	1
134	JMD45LPF-B134	20213A	I shaft		1
135	JMD45LPF-B135		Key	4x16	2
136	JMD45LPF-B136		Key	5x30	1
137	JMD45LPF-B137		Bearing	51103	1
138	JMD45LPF-B138	20104A	Flange		1
139	JMD45LPF-B139		Screw	M5x16	3
140	JMD45LPF-B140		Retaining ring	17	1

JMD-45LPF Base Parts - C

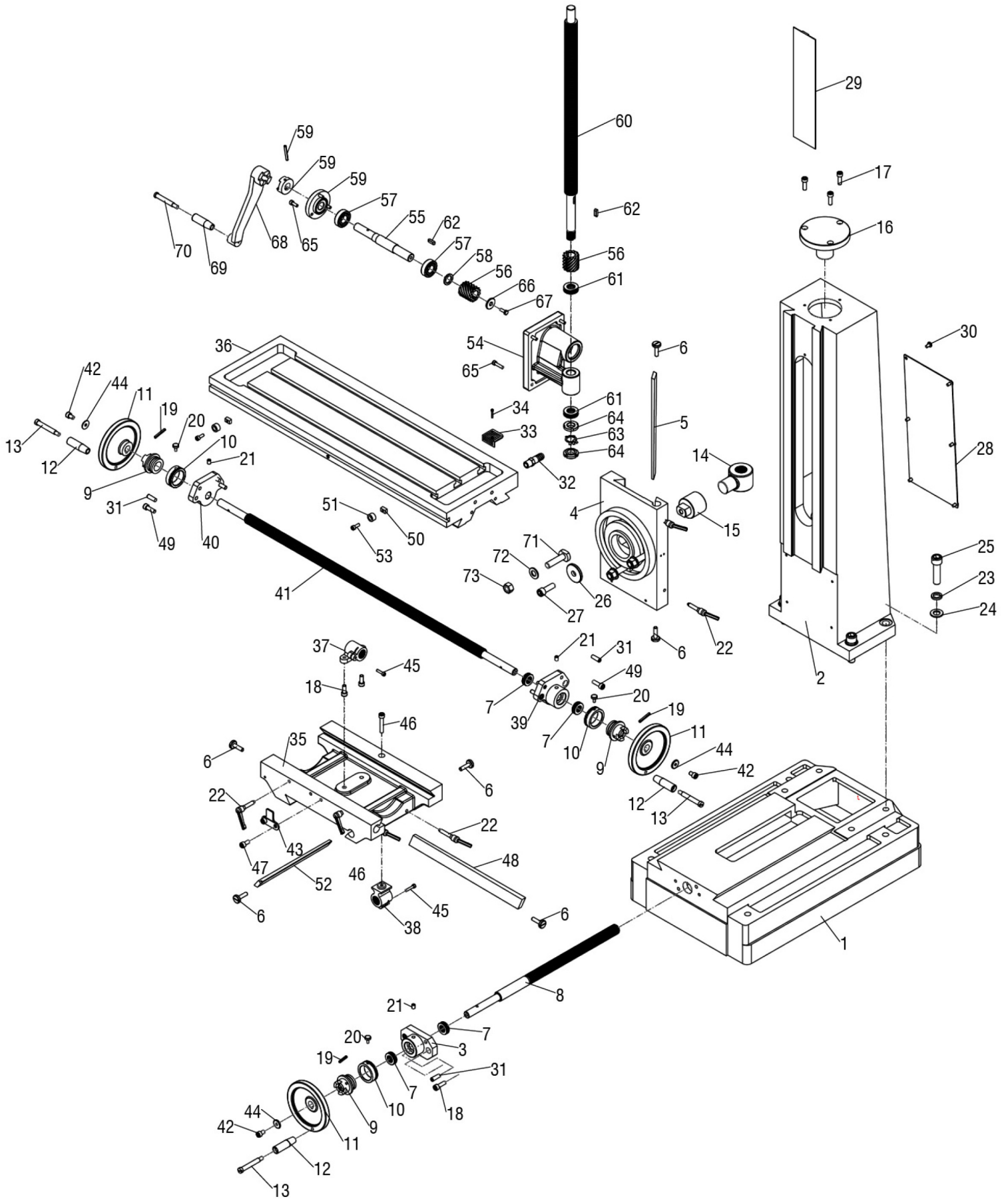

JMD-45LPF Base Parts - C

No.	Part No.	Code	Name	Size	Qty.
1	JMD45LPF-C1	10010	Base		1
2	JMD45LPF-C2	10013	Column		1
3	JMD45LPF-C3	10021	Square flange		1
4	JMD45LPF-C4	10016	Raise and lower base		1
5	JMD45LPF-C5	10025	Gib strip		1
6	JMD45LPF-C6	10106	Screw		6
7	JMD45LPF-C7		Bearing	51103	4
8	JMD45LPF-C8	10104	Table screw		1
9	JMD45LPF-C9	10102	Dial clutch		3
10	JMD45LPF-C10	10111	Graduated plate		3
11	JMD45LPF-C11	10301	Wheel		3
12	JMD45LPF-C12	20305-1B	Turn handle		3
13	JMD45LPF-C13	20305-1B	Screw		3
14	JMD45LPF-C14	10024	nut		1
15	JMD45LPF-C15	10117	Nut bracket		1
16	JMD45LPF-C16	10014	cover		1
17	JMD45LPF-C17		Screw	M8x20	3
18	JMD45LPF-C18		Screw	M8x25	4
19	JMD45LPF-C19		Pin	5x35	3
20	JMD45LPF-C20	10107	screw		2
21	JMD45LPF-C21		Oil cup	8	5
22	JMD45LPF-C22		Fixed handle	M8	6
23	JMD45LPF-C23		Washer	16	4
24	JMD45LPF-C24		Washer	16	4
25	JMD45LPF-C25		Bolt	M16x60	4
26	JMD45LPF-C26	10120	washer		1
27	JMD45LPF-C27		Screw	M12x35	1
28	JMD45LPF-C28	10119	plate		1
29	JMD45LPF-C29	10124	Protecting cover		1
30	JMD45LPF-C30		Screw	M6x12	6
31	JMD45LPF-C31		Pin	8x30	6
32	JMD45LPF-C32		Pipe joint		1
33	JMD45LPF-C33		Filter screen		1
34	JMD45LPF-C34		Screw	M3x25	2
35	JMD45LPF-C35	10011	Center base		1
36	JMD45LPF-C36	10012	Table		1
37	JMD45LPF-C37	10202	Table nut		1
38	JMD45LPF-C38	10203	Table base nut		1
39	JMD45LPF-C39	10020	Right flange		1
40	JMD45LPF-C40	10019	Left flange		1

Certificate of Inspection
for
Geared Head Milling and Drilling Machine
Model JMD-45LPF

Dispatch No.:

The machine has been qualified and may be permitted to dispatch

Head of Inspection Depart _____ Date _____

Director _____ Date _____

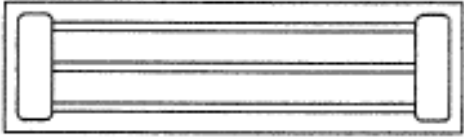
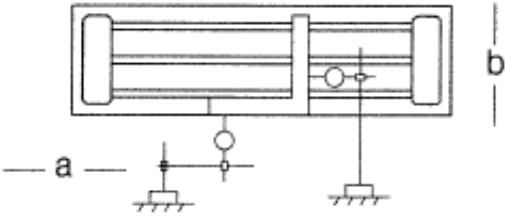
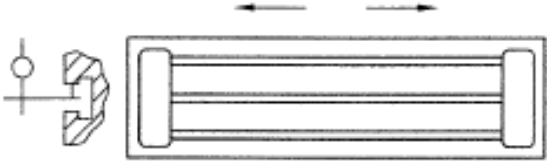
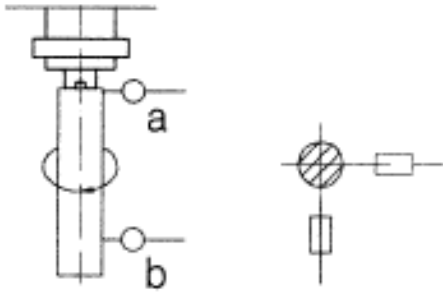
<p style="text-align: center;">ACCURACY TEST FOR MILLING & DRILLING MACHINE</p>		<p style="text-align: center;">Total 2</p>	
		<p style="text-align: center;">P1</p>	
No.	Checking items	Tolerance	Error tested
G1	<p>The flatness of worktable surface</p> 	<p>0.025 for any tesred length 200 Max 0.08</p>	
G2	<p>Squareness of worktable longitudinal movement to cross movement</p> 	<p>0.04/300</p>	
G3	<p>Parallelism of worktable longitudinal movement to the base T-slot</p> 	<p>0.05</p>	
G4	<p>Ran-out of spindle hole center line</p> 	<p>a)Near spindle nose 0.015 b)At a distance of 100 form spindle nose 0.02</p>	

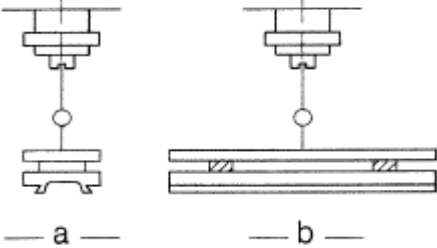
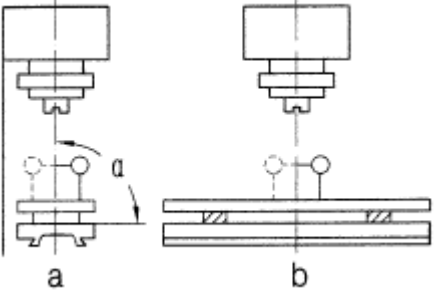
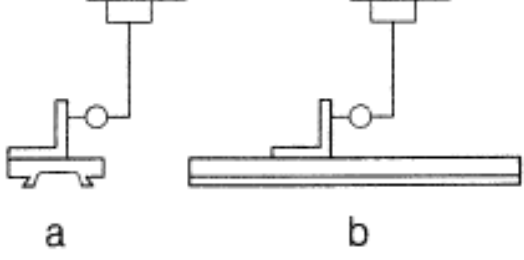
<p style="text-align: center;">ACCURACY TEST FOR MILLING & DRILLING MACHINE</p>		<p style="text-align: center;">Total 2</p>	
		<p style="text-align: center;">P1</p>	
No.	Checking items	Tolerance	Error tested
<p>G5</p>	<p>Parallelism of worktable movement to worktable surface</p>  <p style="text-align: center;">— a — — b —</p>	<p>a 0.02 for any 100 testing length b 0.03 for any 300 testing Max 0.06</p>	
<p>G6</p>	<p>Squareness of spindle rotating line to worktable surface</p>  <p style="text-align: center;">a b</p>	<p>a 0.05/300 a ≤ 90° b 0.05/300</p>	
<p>G7</p>	<p>Squareness of spindle sleeve vertical movement to worktable surface</p>  <p style="text-align: center;">a b</p>	<p>a 0.05/100 b 0.05/100</p>	

PACKING LIST FOR

GEARED HEAD DRILLING & MILLING MACHINE JMD-45LPF

Series No :		Dimension :			
G/W :		N/W :			
No.	Name	Spec	Model	Quantity	Remark
1	Milling & drilling machine		JMD-45LPF	1	
2	Draw bar	M12		1	
3	Adapter	ISO30/MT3		1	
4	Taper shank for drilling chuck	ISO30/B16		1	
5	Drilling chuck	$\Phi 1 \sim \Phi 13$		1	
6	T slot bolt	M12×55		2	
7	Washer	12		2	
8	Nut	M12		2	
9	Inner hexagonal spanner	2.5/3、4、5		4	
10	Tilted wedge			1+1	
11	Spanner	19-22		1	
12	Oil gun			1	
13	Handle			3	
14	Hand wheel			3	
15	Screw	M6x12		3	
16	Washer	6		3	
17	Instruction Manual			1	
18	Certificate of inspection			1	
19	Packing list			1	

Packing inspector_____

Date_____